

Product Data

Hydrophones — Types 8103, 8104, 8105 and 8106

USES:

- Calibration reference standard
- Ultrasonic measurements in liquids
- Cavitation measurements
- Laboratory and industrial measurements in liquids and gases
- As underwater projectors (8103, 8104 and 8105)
- Noise measurements in humid and polluted atmospheres

FEATURES:

- Frequency ranges from 0.1 Hz to 180 kHz
- Individually calibrated; traceable to NIST
- Flat frequency response over wide range
- Omnidirectional over wide frequency range
- Working pressures up to 9.8×10^6 Pa (100 atm. [1000 m])
- Shielded-element construction
- Highly corrosion resistant

ADDITIONAL FEATURES 8103:

- Very small size (50×9.5 mm)
- -3 dB limit in air at 15 kHz
- Double-shielded low-noise integral cable

ADDITIONAL FEATURES 8105:

- Omnidirectional over full frequency range
- No metallic parts exposed
- -3 dB limit in air at 7 kHz

ADDITIONAL FEATURES 8106:

- High sensitivity: -174 dB re 1 V/μPa
- Built-in preamplifier with provision for insert-voltage calibration
- Durable construction
- Equivalent noise level well below sea-state zero

The Brüel & Kjær range of hydrophones is a range of individually calibrated waterborne-sound transducers which have a flat frequency response and are omnidirectional over a wide frequency range. Their construction is such that they are absolutely waterproof and have good corrosion resistance. There are four types of Brüel & Kjær Hydrophone:

Type **8103** is suitable for laboratory and industrial use and particularly for the acoustic study of marine animals or for cavitation measurements.

Type **8104** is ideal for calibration purposes.

Type **8105** is a robust spherical hydrophone usable down to 1000 m ocean depth with excellent directional characteristics, being omnidirectional over 270° in the axial plane and 360° in the radial plane.

Type **8106** has a built-in amplifier which gives a signal suitable for transmission over long underwater cables. It is usable down to 1000 m ocean depth.

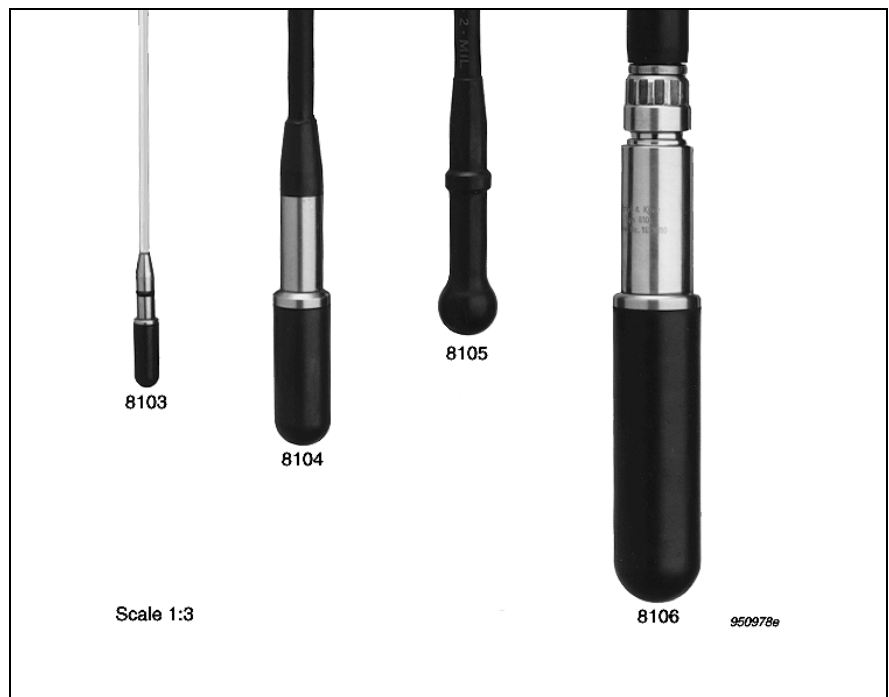

The Brüel & Kjær range of water-borne-sound transducers consists of the following:

Hydrophone Type 8103. A small-size, high-sensitivity transducer for making absolute sound measurements over the frequency range 0.1 Hz to 180 kHz with a receiving sensitivity of -211 dB re 1 V/ μ Pa. It has a high sensitivity relative to its size and good all-round characteristics which make it generally applicable to laboratory, industrial and educational use. The 8103's high-frequency response is especially valuable when making acoustic investigations of marine animals and in the measurement of the pressure-distribution patterns in ultrasonic-cleaning baths. It is also useful for cavitation measurements. Fig. 1 indicates the major features of the 8103.

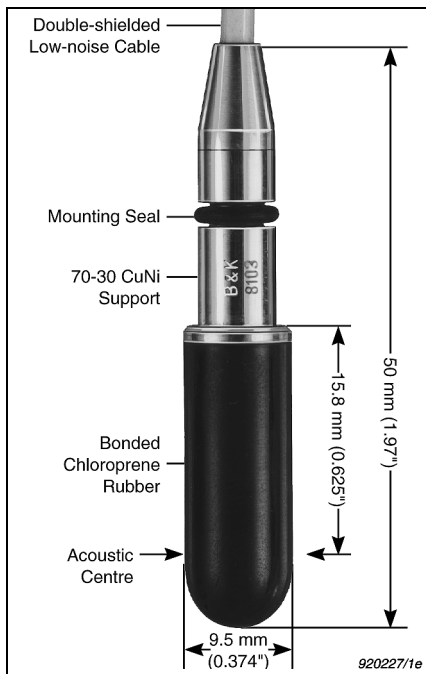

Fig. 1 Hydrophone Type 8103

Hydrophone Type 8104. A wide-range standard measuring transducer for making absolute sound measurements over the frequency range 0.1 Hz to 120 kHz with a receiving sensitivity of -205 dB re 1 V/ μ Pa. It can also be used as a sound transmitter (projector) which makes it ideal for calibration purposes by the reciprocity, calibrated-projector and comparison methods. The main features of the 8104 are shown in Fig. 2.

Hydrophone Type 8105. A small, spherical transducer for making absolute sound measurements over the frequency range 0.1 Hz to 160 kHz with a receiving sensitivity of -205 dB

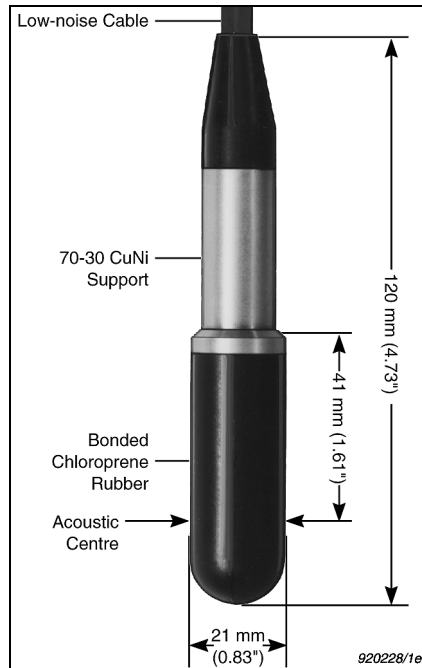

Fig. 2 Hydrophone Type 8104

re 1 V/ μ Pa. It is rugged, being capable of withstanding pressures of up to 10^7 Pa (100 atm.; 1000 m (3250 ft.) ocean depth). This hydrophone has excellent directional characteristics: at 100 kHz, it is omnidirectional over 360° in the x - y (radial) plane and 270° in the x - z (axial) plane. The Type 8105 is illustrated in Fig. 3.

Hydrophone Type 8106. A wide-range, general-purpose transducer for making absolute sound measurements over the frequency range 7 Hz to 80 kHz with a receiving sensitivity of -174 dB re 1 V/ μ Pa. The hydrophone is capable of withstanding high static pressure, the operational upper limit being 10^7 Pa (100 atm.; 1000 m (3250 ft.) ocean depth). A built-in high-quality, thick-film, low-noise, 10 dB preamplifier provides signal conditioning for transmission over long underwater cables. The preamplifier features a 7 Hz high-pass filter and an insert-voltage calibration facility, but does not allow the hydrophone to be used as a projector. An integrated watertight connector allows quick disconnection of the cable and makes replacements and storage very easy. Type 8106 is shown in Fig. 4.

Construction

The four Brüel & Kjær Hydrophones are piezoelectric transducers, i.e., they use piezoelectric ceramics as

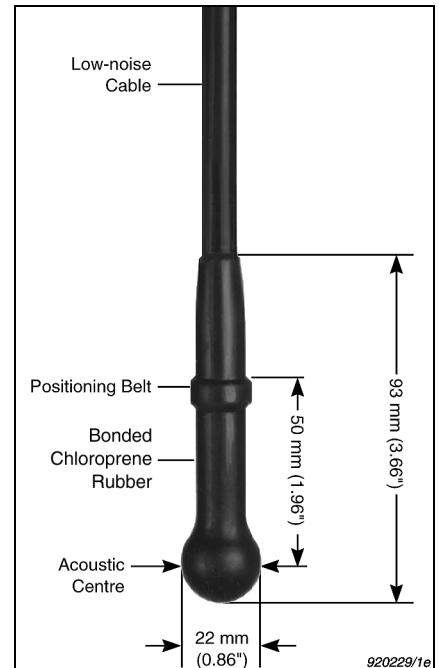

Fig. 3 Hydrophone Type 8105

sensing elements. The piezoelectric sensing element and its internal supporting structure are permanently bonded into sound-transparent polychloroprene rubber.

The support body of Hydrophones Types 8103 and 8104 is made from a 70-30 Copper-Nickel alloy. Type

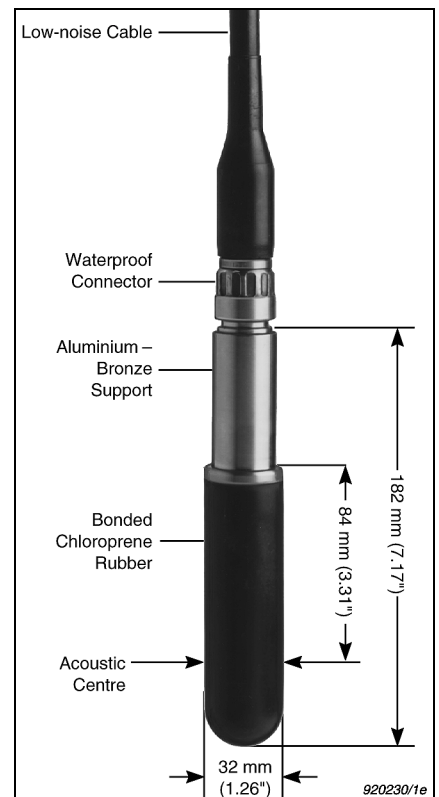

Fig. 4 Hydrophone Type 8106

8106's support body is made of Aluminium-Bronze alloy $\text{CuAl}_{10}\text{Ni}_5\text{Fe}_4$ (ISO 428). Both alloys have extremely high corrosion resistance to virtually all hostile environments, and very good anti-fouling properties when immersed in seawater. Type 8105 has no metal parts exposed.

The internal support is mechanically and electrically isolated from the metal housing, being coupled only by synthetic rubber. This provides vibration isolation of the sensing element. Except for Type 8106, the hydrophones are equipped with an integral cable, the shield of which is connected to the internal support/housing, thus providing electrical shielding for the sensing element. Note that Type 8103 has its internal support and metal housing connected at the plug end of the cable.

Cables and Connectors

Special care has been taken in the production of Brüel & Kjær Hydrophone Cables in order to obtain good electrical shielding. This enables the hydrophones to be used in air and in water tanks where the electrical potential of the water is different from the ground potential, as well as in cases of high electromagnetic interference.

The miniature Hydrophone Type 8103 is fitted with 6 m integral double-shielded cable terminated with a Brüel & Kjær Miniature Plug JP 0056. In cases of high electromagnetic interference, a metal screen can be clamped onto the metal support. This support is connected internally to the outer shield of the cable which is in turn connected to the inner shield of the terminating plug end of the cable.

Hydrophones Types 8104 and 8105 have integral 10 m cables (AC 0034) fulfilling MIL-C-915. These are fitted with BNC plugs. For use at greater depths (up to 1000 m with the 8105), MIL-C-915 standard extension cables of up to 300 m are available to order. These can be fitted to the hydrophone's integral cable with Brüel & Kjær Waterproof Connectors JP 0415 (male) and JJ 0415 (female), which are suitable for use with Hydrophones Types 8104 and 8105. Pictorial assembly instructions are provided with each male or female connector set. We recommend that the male connector (JP 0415) is fitted to the cable on the hydrophone.

Hydrophone Type 8106 is supplied without a cable. A 10 m Cable

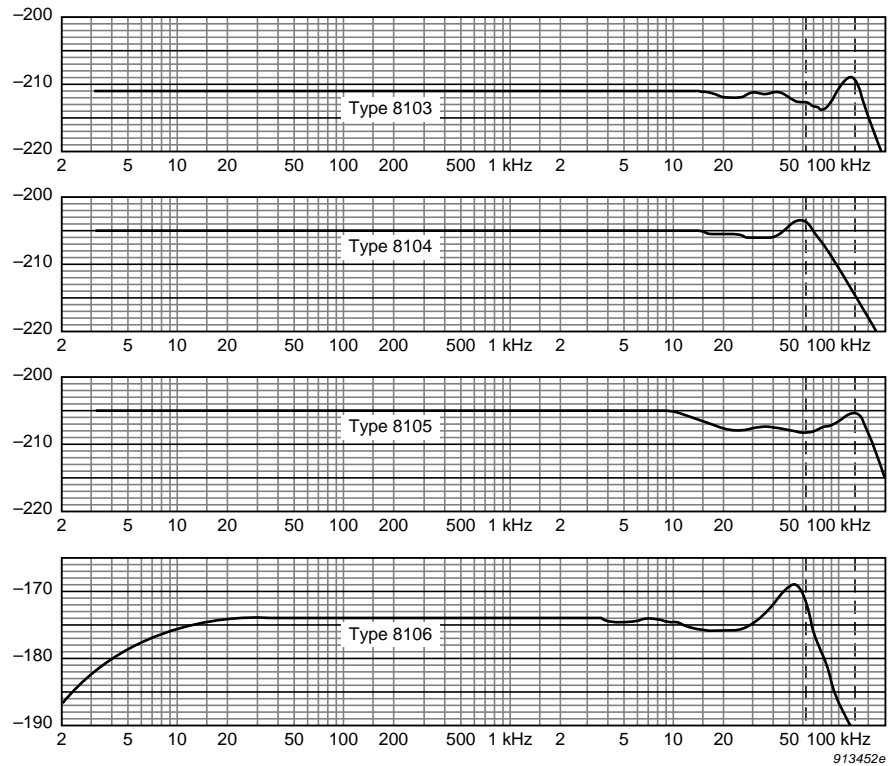

Fig. 5 Typical receiving frequency characteristics of Hydrophones Types 8103, 8104, 8105 and 8106 (dB re 1V/ μPa)

AO 0390 (a 10 m length of AC 0101: see below) mounted with a watertight Connecting Plug JP 0735 and a Brüel & Kjær 7-pin Plug JP 0717 is available for direct connection to the Preamp. socket of Brüel & Kjær Measuring Amplifiers and Frequency Analyzers. The Connecting Plug JP 0735 fits the 7-pin female connector (corresponding to the Jupiter® connector series 10M) which is an integrated part of the hydrophone's bronze support.

For use of Type 8106 at depths greater than 10 m, Hydrophone Cable AC 0101 can be supplied in continuous lengths of up to 300 m. This cable is a screened, 4-core cable with built-in KEVLAR® reinforcement. AC 0101 can tolerate high loads – 1300 N in service, with a breaking load of 2600 N. This makes the cable strong enough to be self-supporting for measurements at ocean depths of 1000 m.

Frequency Response and Directivity Patterns

Typical frequency responses of the hydrophones are shown in Fig. 5. These were measured in a water tank in free-field conditions achieved by means of pulse techniques using a

factory calibration Gating System Type 4440.

The hydrophones have very good omnidirectional characteristics. Typical directivity patterns of the hydrophones in water are shown in Fig. 6. These polar directivity patterns were measured in free-field conditions achieved by means of gating techniques in a water tank. This method requires a standard hydrophone as a projector and the unknown hydrophone as the receiver whose polar directivity pattern is to be determined.

Calibration System

Fig. 7 shows a system which can be used for measurement of the frequency response of hydrophones and for calibration of hydrophone systems. With additional components, the directivity pattern is also included. The PULSE system Type 3560 is a PC-based system including a front-end with generator and input modules, Power Amplifier Type 2713, Turntable Type 3922, Turntable Interface Type 5997, Current Probe WB 1490 and a PC with software and Windows operating system. The principle is the well-known gating technique, where a tone burst is sent out from the generator, amplified in the power amplifier and sent to the transmitter (in

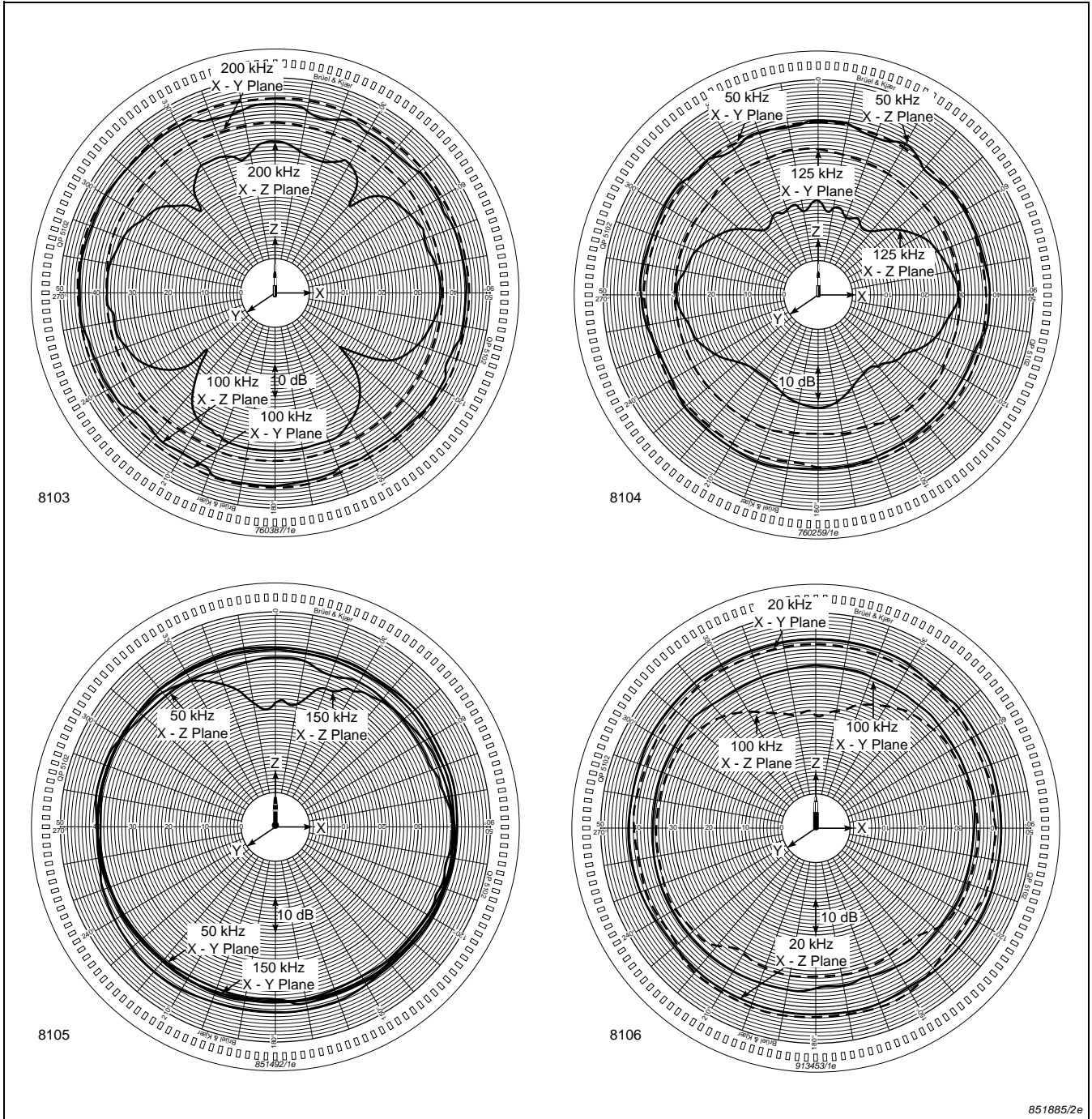

Fig.6 Typical directivity patterns of Hydrophones Types 8103, 8104, 8105 and 8106

this case a Hydrophone Type 8104). The signal received from another hydrophone is amplified and the time signal is shown on the PC monitor. A delay due to the distance between transmitter and receiver and a gating period depending on frequency range and tank dimensions is set up in the analyzer in order to analyze on a stable direct signal without transients or reflections from walls. The measurements are performed at specified frequencies and a complete report is

available. Directivity patterns can be found with software for the turntable. All responses include amplitude and phase. This system can be used for reciprocity, comparison and impedance measurements.

Calibration

Each Brüel & Kjær Hydrophone is submitted to an extensive ageing and temperature stabilizing procedure be-

fore being individually calibrated. Individual calibration data and frequency response curves are supplied with each hydrophone. The receiving sensitivity calibration of Brüel & Kjær Hydrophones is traceable to NIST.

A convenient calibration check at low frequencies can be performed using Brüel & Kjær Hydrophone Calibrator Type 4229 (the sensitivity of a hydrophone is the same in air as in water for low frequencies). This pro-

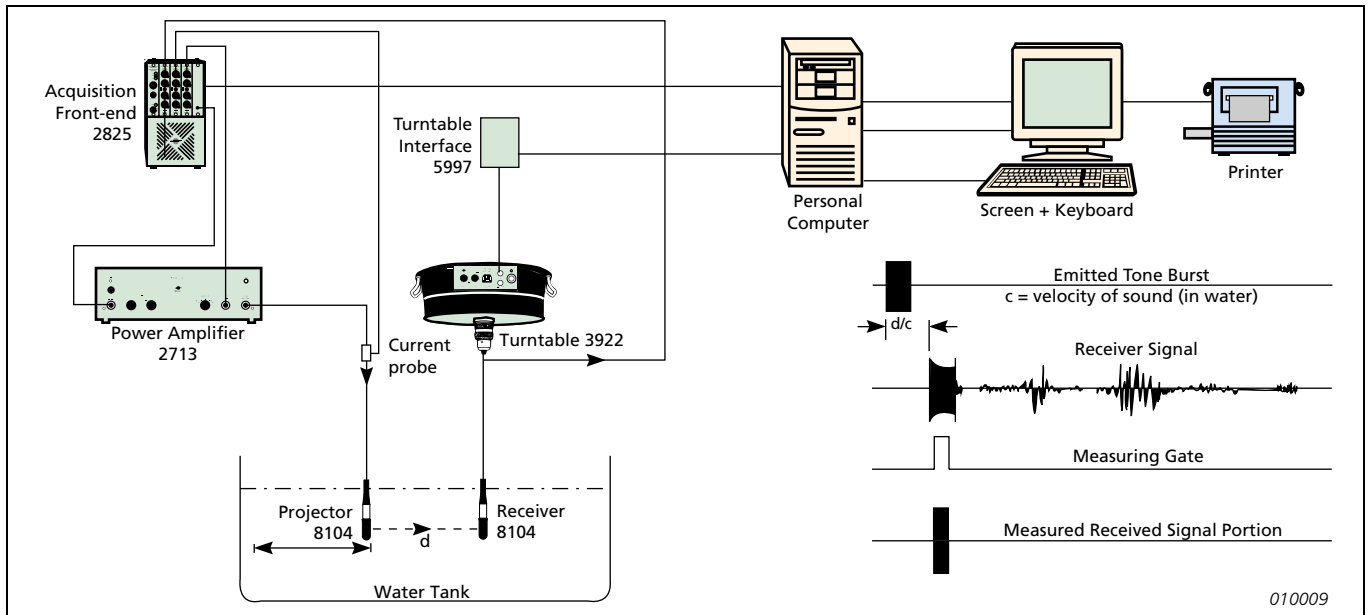

Fig.7 Hydrophone Calibration System: Set-up for Calibration in the 4kHz to 100kHz range using PULSE Multi-analyzer System Type 3560

vides a rapid and easy method for air calibration of sound measuring systems terminating in Brüel & Kjær Hydrophones. Type 4229 is battery powered and can be used both in the laboratory and in the field.

The principle of operation of the 4229 is the production of a sound pressure in the coupler cavity by four pistons which oscillate back and forth in phase. A frequency of 251.2 Hz is produced which is electronically maintained within $\pm 0.1\%$.

Fig. 8 shows sectional drawings of the Calibrator. The calibrator couplers are shown fitted with their respective Brüel & Kjær Hydrophones. The typical sound pressure levels produced in the coupler volumes are 166, 162, 151.5 and 152 dB re $1 \mu\text{Pa}$ for the 8103, 8104, 8105 and 8106, respectively. Note that the sound pressure level in the coupler volume can be monitored with a $1/2$ " microphones (see inset of Fig. 8), thus enabling the calibration to be traceable to NIST.

Note: The 8106 coupler, WA 0658, is available separately. The other couplers are supplied with Type 4229.

A barometer is supplied with the 4229 giving the atmospheric pressure correction in dB in the range 0.65×10^5 to 1.08×10^5 Pa (650 to 1080 hPa), i.e. -3.85 to $+0.55$ dB.

Measurements

Before measurements are taken, the high-impedance output signals from Hydrophones Types 8103, 8104 and 8105 should be routed through a signal-conditioning amplifier. Although the entire Brüel & Kjær range of accelerometer preamplifiers is suitable, Conditioning Amplifier Type 2635 or Measuring Amplifier Type 2525 is recommended. These amplifiers feature sensitivity adjustment to give convenient output values (for example 0.1 or 1V/Unit) and have a wide frequency range, and adjustable low-pass and high-pass filters. Note that Type 2635 is battery powered and portable. For technical details of these preamplifiers, the reader is referred to their respective product data sheets.

When using Type 8104 or 8105 with Measuring Amplifier Type 2525, BNC to TNC Adaptor JP 0226 must be used. The built-in preamplifier of Hydrophone Type 8106 provides an output signal which does not require further conditioning. The 8106 can be directly plugged into the Preamplifier socket of the Brüel & Kjær range of Measuring Amplifiers and Frequency Analyzers, with 7-pin Brüel & Kjær sockets, which supply the necessary voltages. Dual Microphone Supply Type 5935 must be ordered with modification WH 3125 and requires an external supply. Microphone

Multiplexer Type 2822 must be ordered with modification WH 3127.

Use as Projectors

The piezoelectric effect of the sensing element is reversible, i.e., mechanical excitation causes an electrical output, and conversely, an applied alternating voltage causes corresponding mechanical excitation. Therefore, Hydrophones Types 8103, 8104 and 8105 (but not Hydrophone Type 8106 because it also includes a built-in preamplifier), can be used as sound transmitters (projectors), for both measurement and reciprocity calibration. Transmitting responses to voltage for Hydrophones Types 8103, 8104 and 8105 in water are shown in Fig. 9. Note the 12 dB/octave slope which is typical for piezoelectric hydrophones driven with constant voltage input.

When hydrophones are used as projectors, the driving signal requires power amplification. Brüel & Kjær Power Amplifier Type 2713 has been especially designed for driving Hydrophones Types 8103, 8104 and 8105 as projectors, but is also useful for driving other highly reactive loads. Type 2713 is a low-noise 100 VA power amplifier with a frequency range extending from 10 Hz up to 200 kHz, and a gain continuously adjustable between 0 and 60 dB

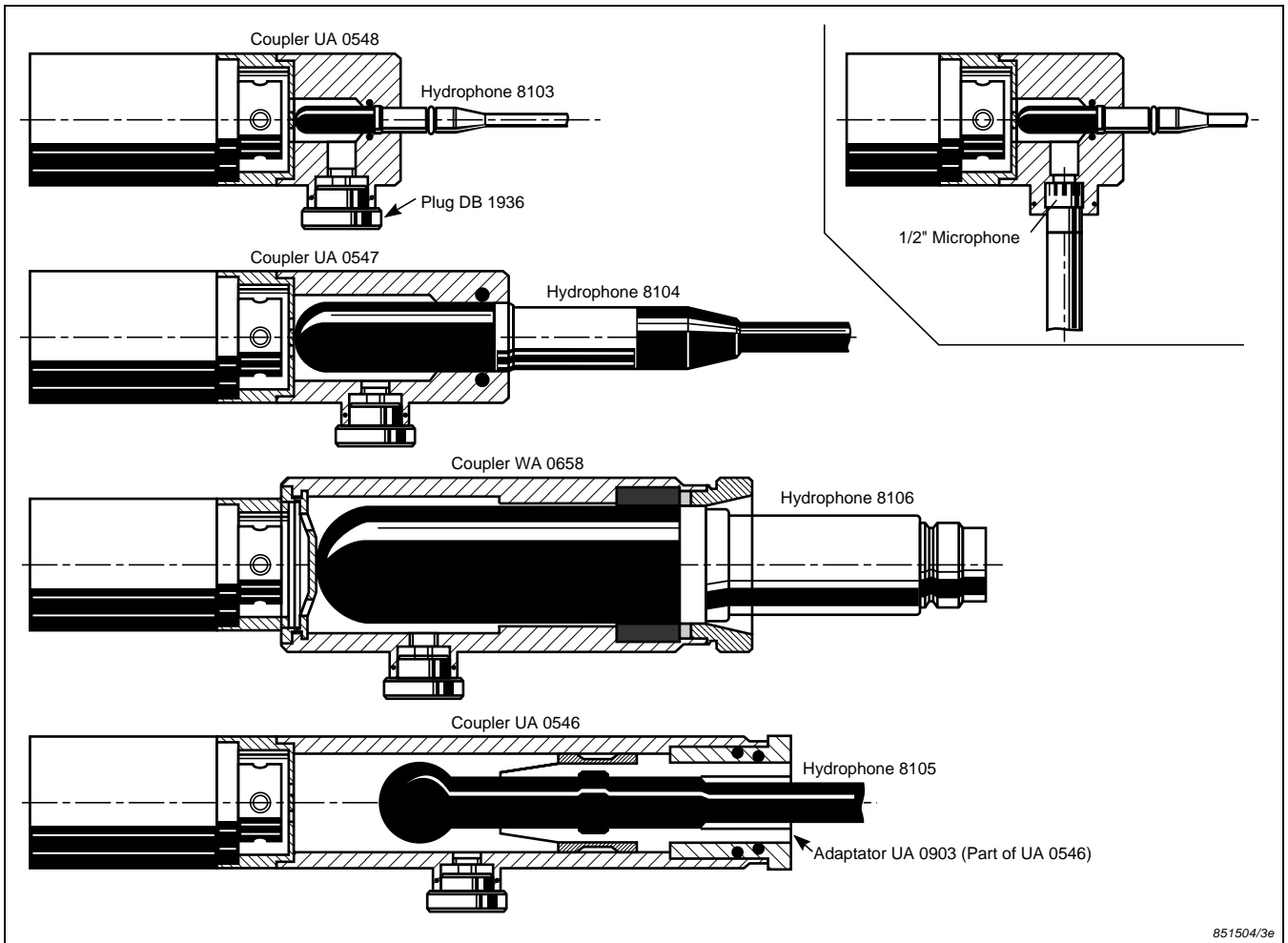

851504/3e

Fig.8 Mounting of Brüel & Kjær Hydrophones Types 8103, 8104, 8105 and 8106 on their respective couplers with Calibrator Type 4229. The inset shows a 1/2" microphone inserted into a coupler for monitoring the sound pressure level

over six 10 dB ranges. It also features selectable maximum output voltage limits, as well as extensive protective functions to prevent damage to both the amplifier and the transducer.

A feature of the Sine Generator 1051 is that its amplitude memory can be programmed with the inverse

of the projector hydrophone's transmitting response (Fig. 9). The combination of drive signal and projector characteristic then results in constant SPL with frequency. The set-up for this method of calibration is the same as that shown in Fig. 7.

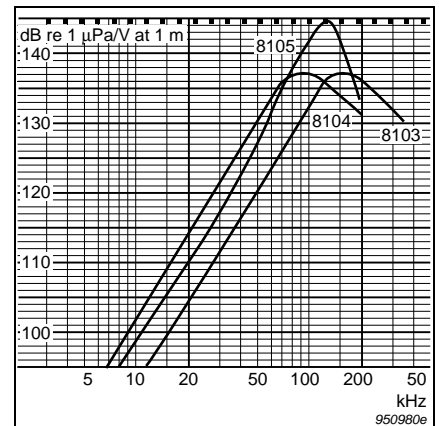

Fig.9 Typical transmitting response to voltage of Types 8103, 8104 and 8105

Specifications 8103, 8104, 8105 and 8106

Type	8103	8104	8105	8106
Voltage sensitivity [*] : (with cable) at 20°C	30 μV/Pa ±8 μV (-211 dB re 1 V/μPa ±2 dB)	56 μV/Pa ±15 μV (-205 dB re 1 V/μPa ±2 dB)		2000 μV/Pa ±500 μV (-174 dB re 1 V/μPa ±3 dB)
Charge sensitivity [*] :	0.12 pC/Pa	0.44 pC/Pa	0.42 pC/Pa	
Capacitance [*] : (with integral cable)	3850 pF	7800 pF	7500 pF	
Frequency range [*] (re 250 Hz):	(+1.5 dB) 0.1 Hz to 100 kHz (-6.0 dB) (+3.5 dB) 0.1 Hz to 180 kHz (-12.5 dB)	(±4.0 dB) 0.1 Hz to 80 kHz (+4.0 dB) 0.1 Hz to 120 kHz (-12.0 dB)	(+1.0 dB) 0.1 Hz to 100 kHz (-6.5 dB) (+3.5 dB) 0.1 Hz to 160 kHz (-10.0 dB)	(+0.5 dB) 10 Hz to 10 kHz (-3.0 dB) (+0.5 dB) 7 Hz to 30 kHz (-8.0 dB)
Horizontal directivity [†] : (radial xy plane)	±2 dB at 100 kHz			±2 dB at 20 kHz
Vertical directivity: (axial xz plane)	±4 dB at 100 kHz	±2 dB at 50 kHz	±2 dB over 270° at 100 kHz	±3 dB at 20 kHz
Leakage resistance [*] : (at 20°C)	>2500 MΩ			
Operating temperature range Short-term: Continuous:	-40°C to +120°C -40°C to +80°C			-10°C to +60°C
Sensitivity change with temperature Charge: Voltage:	0 to +0.03 dB/°C 0 to -0.03 dB/°C	0 to +0.03 dB/°C 0 to -0.04 dB/°C	0 to +0.03 dB/°C 0 to -0.03 dB/°C	- 0 to +0.01 dB/°C
Max. operating static pressure:	252 dB = 4 × 10 ⁶ Pa = 40 atm. = 400 m ocean depth		260 dB = 9.8 × 10 ⁶ Pa = 100 atm. = 1000 m ocean depth	
Sensitivity change with static pressure:	0 to -3 × 10 ⁻⁷ dB/Pa (0 to -0.03 dB/atm.)			0 to 1 × 10 ⁻⁷ dB/Pa 0 to 0.01 dB/atm.
Allowable total radiation dose:	5 × 10 ⁷ Rad.			
Dimensions: Length: Body dia:	50 mm (1.97") 9.5 mm (0.37")	120 mm (4.73") 21 mm (0.83")	93 mm (3.66") 22 mm (0.87")	182 mm (7.17") 32 mm (1.26")
Weight: (including integral cable)	170 g (0.37 lb)	1.6 kg (3.5 lb)		382 g (0.84 lb)
Integral cable:	6 m waterproof low-noise double-shielded teflon cable with standard miniature coaxial plug	10 m waterblocked low-noise shielded cable to MIL-C-915 with BNC plug		

* Nominal value, each hydrophone is supplied with its own calibration data

† See polar directivity given in Fig. 7

Note: All values are typical at 25°C (77°F), unless measurement uncertainty is specified. All uncertainty values are specified at 2σ (i.e. expanded uncertainty using a coverage factor of 2)

Ordering Information

Optional Accessories	Type 8106:	Adaptors:
Types 8104 and 8105: AC 0034: Waterblocked low-noise shielded extension cable to MIL-C-915 available to any length up to 300 m JP 0415: Male underwater connector (for integral cable) JJ 0415: Female underwater connector (for extension cable) JP 0108: BNC connector for extension cable	WB 0850: Insert-voltage Junction Unit AC 0101: Watertight, shielded 4-core cable, Kevlar reinforced. Any length up to 300 m AO 0390: 10 m of AC 0101, with JP 0735 and JP 0717 JP 0717: 7-pin Brüel & Kjær input connector JP 0744: Male underwater connector for Extension Cable AC 0038 JP 0735: Male underwater connector (for extension cable) JJ 0738: Female underwater connector (for underwater extension cable)	JP 0145: 10 – 32 UNF to BNC JP 0226: BNC to TNC JP 0162: 10 – 32 UNF to TNC JJ 2617: 10 – 32 UNF to 1/2" mic. amp WL 1260: 7 pin B&K to 7 pin LEMO General: 4229: Hydrophone Calibrator Cables: See next page
		* Type 8106 requires Adaptor WA 0658, available separately

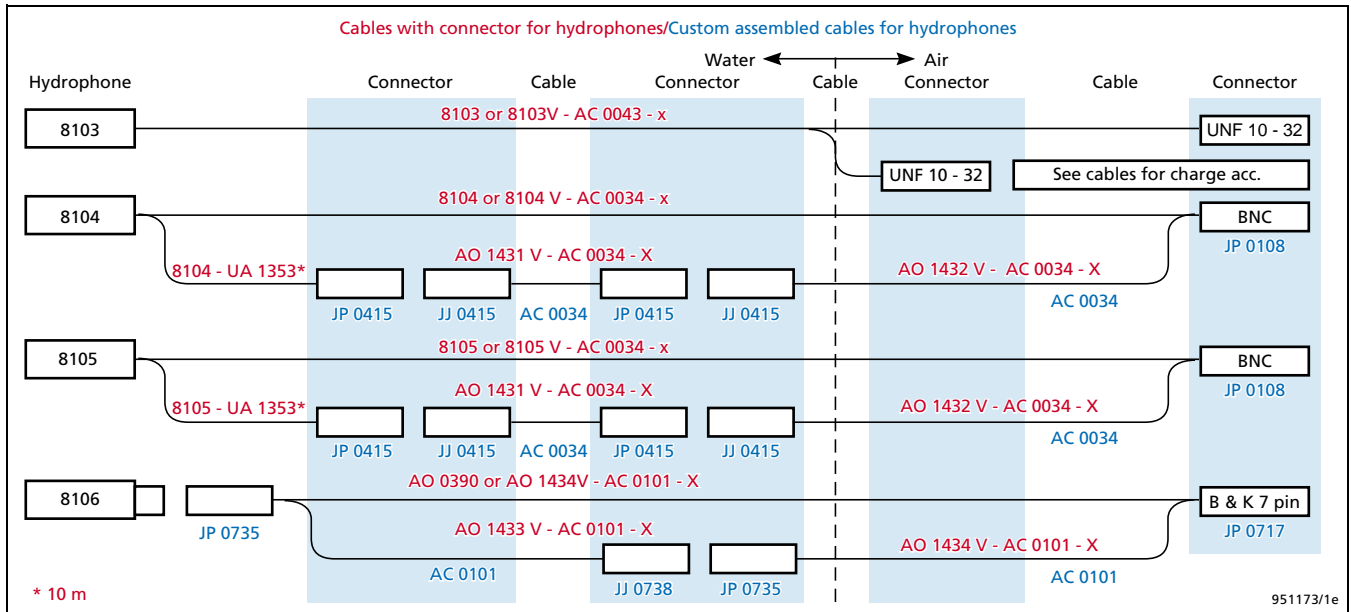

Additional Specifications 8106

MAX. OUTPUT SIGNAL:
 12 V supply: 3.5 V or 28 mA
 24 V supply: 7.0 V or 28 mA

MAX. POWER OUTPUT:
 50 mW

OUTPUT IMPEDANCE:
 <30 Ω

HIGH-PASS FILTER:
 -3 dB at 7 Hz (±2 Hz)

DC RIPPLE REJECTION:
 20 Hz to 20 kHz: 70 dB

OVERLOAD SOUND PRESSURE LEVEL:
 12 V supply: 182 dB re 1 μPa
 24 V supply: 188 dB re 1 μPa

Power Supply

SUPPLY VOLTAGE:
 12 to 24 VDC

POWER CONSUMPTION:
 6 mA without load

Note: All values are typical at 25°C (77°F), unless measurement uncertainty is specified. All uncertainty values are specified at 2σ (i.e. expanded uncertainty using a coverage factor of 2)

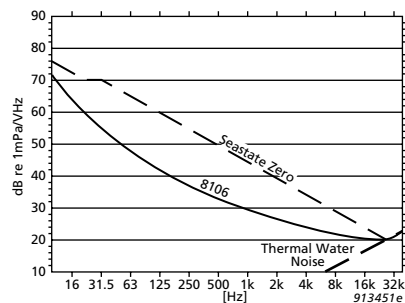

Fig.10 Typical equivalent noise pressure level of Type 8106

COMPLIANCE WITH STANDARDS:

	CE-mark indicates compliance with: EMC Directive IEC 61010-1
Safety	EN 61010-1 and IEC 1010-1: Safety requirements for electrical equipment for measurement, control and laboratory use.
EMC Emission	EN 50081-1: Generic emission standard. Part 1: Residential, commercial and light industry. EN 50081-2: Generic emission standard. Part 2: Industrial environment. CISPR 22: Radio disturbance characteristics of information technology equipment. Class B Limits. FCC Class B limits.
EMC Immunity	EN 50082-1: Generic immunity standard. Part 1: Residential, commercial and light industry. EN 50082-2: Generic immunity standard. Part 2: Industrial environment. Note 1: The above is guaranteed using accessories listed in this Product Data sheet only. Note 2: Susceptibility when exposed to levels specified in EN 50082-2. Conducted RF: <30 mV Radiated RF: <120 mV
Temperature	IEC 60068-2-1 & IEC 60068-2-2: Environmental Testing. Cold and Dry Heat. Operating Temperature: -10 to +60°C (+14 to +140°F) Storage Temperature: -40 to +80°C (-40 to +176°F)
Humidity	IEC60068-2-3: Damp Heat: 90% RH (non-condensing at 40°C (104°F))
Mechanical	Non-operating: IEC 60068-2-6: Vibration: 0.3 mm, 20 m/s ² , 10-500 Hz IEC 60068-2-27: Shock: 1000 m/s ² IEC60068-2-29: Bump: 3000 bumps at 250 m/s ²
Enclosure	IEC60529: Protection Provided by Enclosures: IP 68

Brüel&Kjær reserves the right to change specifications and accessories without notice

Brüel & Kjær

HEADQUARTERS: DK-2850 Nærum · Denmark · Telephone: +4545800500 · Fax: +4545801405 · <http://www.bksv.com> · e-mail: info@bksv.com
 Australia (02)9450-2066 · Austria 0043-1-8657400 · Brazil (011)5182-8166 · Canada (514)695-8225 · China (86) 1068029906
 Czech Republic 02-67021100 · Finland (09)755 950 · France (01)69907100 · Germany 06103/7335-0 · Hong Kong 25487486 · Hungary (1)2158305
 Ireland (01)803 7600 · Italy 02 57 68061 · Japan 03-3779-8671 · Republic of Korea (02)3473-0605 · Netherlands (31) 318 559290 · Norway 66771155
 Poland (22)858 9392 · Portugal (1)4711453 · Singapore (65) 377-4512 · Slovak Republic 421 7 544 307 01 · Spain (91)6590820 · Sweden (08)4498600
 Switzerland (0)1 880 70 35 · Taiwan (02)7139303 · United Kingdom (0)1438 739 000 · USA 800 332 2040
 Local representatives and service organisations worldwide